



# Custom ZT410 Guide

User Guide



## Contents

Printer Setup	3
Ribbons	5
Printer Settings	6
Print Troubleshooting	7
Software Setup	7

Note: the only Zebra printer that is suitable for printing and encoding On Metal RFID labels is the “Custom ZT410” printer that has been modified to accommodate the increased thickness of On metal RFID labels tags vs conventional labels. Attempts to use this guide with a regular ZT410 may result in various print issues, such as slipping and tag getting caught within the printer.

Please refer to Zebra and Nice Label/Bartender user guides for detailed instruction.

## Printer Setup

The photographs on the following pages will help to load label rolls in the printer correctly.

1. Load label spool and ensure lock in place with the Media Supply guide arm.

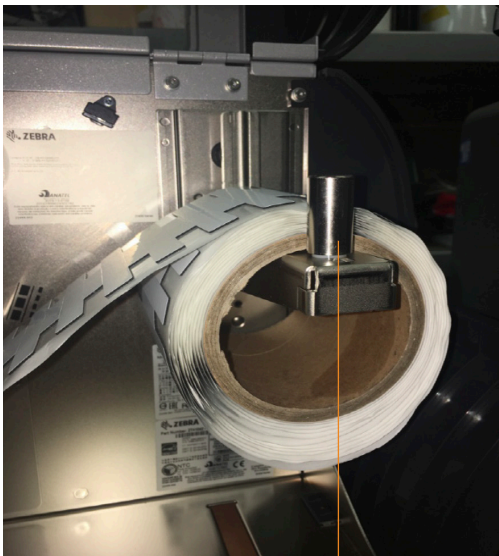

Media Supply Arm

2. Slide Media Guide left until it is just touching edge of the media (release liner).

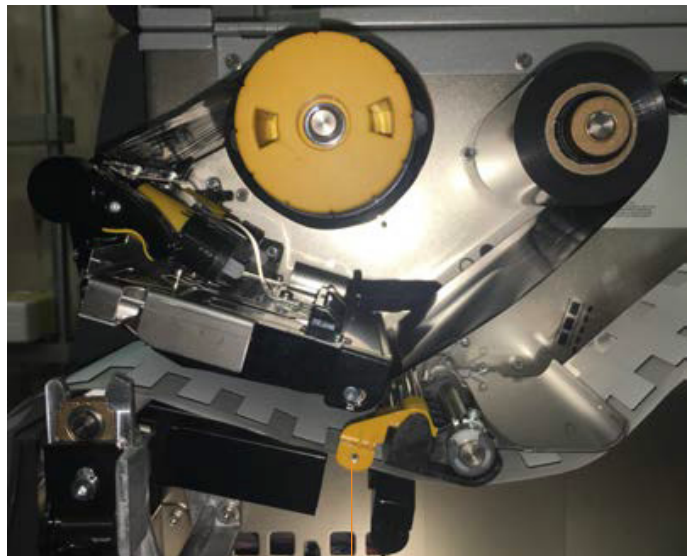

Media Guide

3. Locate the Media Gap Sensor to a position where it is able to detect the start of the RFID label.

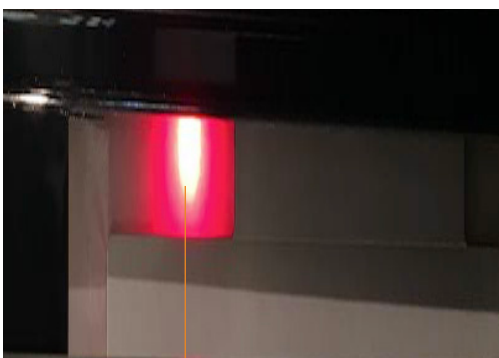

Media Gap Sensor

**4. Feed the labels under the Print Head**

Head pressure dials are located on top of the print head; these should be adjusted so that the print quality is consistent without applying excessive pressure.

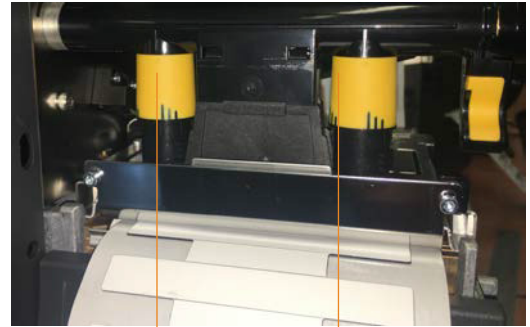

Print head pressure toggles

**5. Final Results**

Image showing final media path. Image from Zebra ZT410 user manual.

From the media hanger (1), feed the media under the dancer assembly (2), through the media sensor (3), and under the printhead assembly (4). Slide the media back until it touches the inside back wall of the media sensor

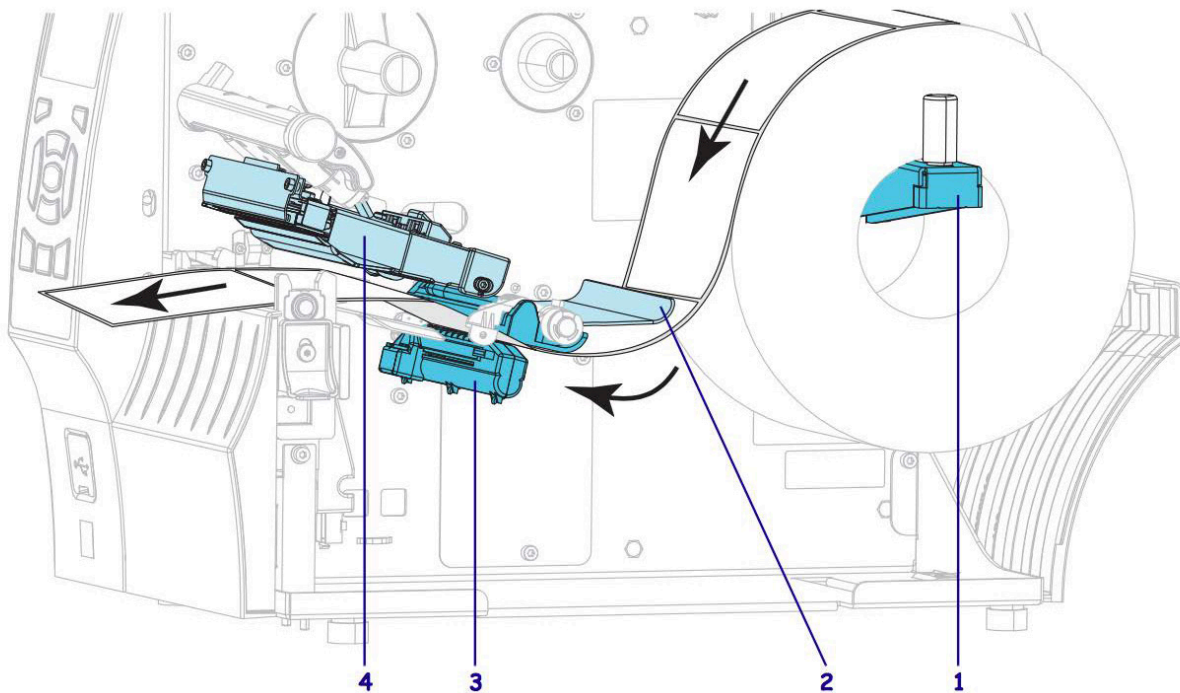

**Omni-ID recommends using a high-quality Resin ribbon:**

Limited supply as standard with Ground Plane and Monza R6-P IC\*

Manufacturer	Product	Type
ITW	B324	Multi-purpose Resin Thermal Transfer



Omni-ID labels are compatible with full resin print ribbons.

Load ribbon into the printer with matt surface visible to the human eye from the front of the printer.

The matt surface is the printing side and correct positioning will ensure correct printing onto the media.

**Loading Ribbon Rolls**

Load Ribbon such that the ink side is facing the print receptive layer on the labels, Image showing ribbon path. Image from Zebra ZT410 user manual.

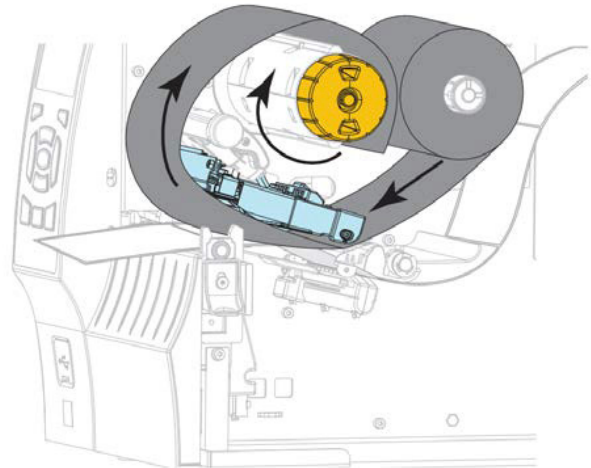

## Printer Settings

This chapter provides specific details and guidelines associated with encoding Omni-ID labels.

1. Setup Printer settings, using main control panel.
2. Optimize RFID encoding settings for Omni-ID labels.

## Printer Setup Menu

**Darkness:** Darkness should be adjusted to achieve optimal print quality based on ribbon used.

**Print speed:** The slowest print speed that is available should be used to print Compound labels. This is typically 2 inches per second.

**Media Type:** Gap / Notch

**Print Method:** Thermal Transfer

**Print Mode:** Tear off

**Tear off:** 0mm

## Media/Ribbon must be calibrated for each Media type correctly

Run media / ribbon calibration when changing media, follow on screen instructions. This can be found under tools menu.

Once media calibration is complete, test by pressing feed a number of times, each time the button is pressed a single label should be feed out of the printer. If multiple labels are feed through the printer, repeat the calibration process.

## RFID settings must be calibrated each time label type is changed

Run RFID calibration, found within RFID menu for printer to detect optimal RF power settings, antenna selection & encoding position.

## Regional tag – IQ 350

Supplied as standard with Ground Plane and Monza R6-P IC

Issue	Possible Cause	Solution
Labels won't feed	Sensor location Sensor setting Media Calibration	Re-locate sensor Check gap sensing in menu Re-calibrate media if necessary.
Barcode not straight	Labels slipping	Increase head pressure or change roller under head
No print at all	Ribbon in upside down Wrong ribbon	Turn ribbon around Change ribbon to known good ribbon.
Partial print on one side	Head pressure	Re-balance
Print blurring	Too much ink	Reduce darkness
Print too light	Too little ink	Increase darkness Slow print speed Increase head pressure both sides.
Printer missing tag between each printed tag.	Gap Levels Incorrect	Re calibrate Gap Levels

## Software Setuo

Recommended software for Custom Zebra ZT410 is either NiceLabel Pro or Bartender. Please Refer to the software's user guide for detailed instructions.

<http://www.nicelabel.com/downloads/user-guides>

<https://www.seagullscientific.com/downloads/label-software-case-studies-and-white-papers/-tab4>



Omni-ID is the leading supplier of passive, low-profile UHF RFID solutions. Through our patented technology, Omni-ID “cracked the code” to overcome the problems traditionally associated with RFID, enabling a broad range of new applications that improve accuracy and efficiency in asset tracking, supply chain management and work-in-process.

Our family of versatile RFID tags works reliably in the harshest environments, including on, off, and near metal and liquids and excels in solving tracking and identification challenges with unprecedented accuracy.

With offices in the USA, UK, Asia and India backed up by a purpose-built manufacturing facility in China, our mission is to drive the widespread adoption of RFID and wider IoT technologies as the optimal tracking and identification devices.

Omni-ID's global presence:

**USA Office:**

333 West Commercial Street  
Suite 333-1500  
East Rochester  
New York 14445

Tel: +1 585 299 5990

**UK Office:**

The Enterprise Centre  
Coxbridge Business Park  
Alton Road  
Farnham, Surrey  
GU10 5EH United Kingdom

Tel: +44 (0)1252 748 020

**Asia Office:**

Omni-ID Technology Trading  
(ShangHai) Co. LTD  
1308 Room Unit B  
Sunyoung Center 28 XuanHua Rd  
ShangHai 205002

Tel: +86 21 5240 0359

**India Office:**

Omni-ID India Private Limited  
# 1007, Mayuresh Square  
Plot No. 17, Sector 15, CBD Belapur  
Navi Mumbai, Maharashtra 400614,  
India

Tel: +91 (0)22 2757 7969

Visit [www.omni-id.com](http://www.omni-id.com) to learn more or email [sales@omni-id.com](mailto:sales@omni-id.com)  
for all product or technology inquiries and we will be pleased to get in touch.

[omni-id.com](http://omni-id.com)